

CNI 508N2 COUPLING NETWORK

COUPLING/DECOUPLING ASSEMBLY FOR UNSHIELDED AND SHIELDED HIGH-SPEED COMMUNICATION LINES UP TO 1GBIT/S



FOR TESTS ACCORDING TO ...

- > EN 61000-4-4
- > EN 61000-4-5
- > EN 61000-6-1
- > EN 61000-6-2
- > IEC 61000-4-4
- > IEC 61000-4-5

COUPLING/DECOUPLING ASSEMBLY FOR UNSHIELDED AND SHIELDED HIGH-SPEED COMMUNICATION LINES

The CNI 508N2 from AMETEK CTS is the first coupling/decoupling network available on the market to couple Surge onto shielded and unshielded high-speed communication lines with data rates up to 1,000MBit/s. Additionally, the CNI 508N2 can be used as a coupling/decoupling network to apply Burst- as well as Surge pulses to unshielded symmetrical interconnection lines. The CNI 508 N2 meets the requirements according Figure 11 and Figure 12 to the standards IEC 61000-4-5 (Ed. 3.0 :2014).

HIGHLIGHTS

- > Coupling to unshielded and shielded lines with up to 4 pairs
- > Data transfer up to 1,000MBit/s
- > Surge test voltage up to 3kV (1.2/50us)
- > Burst test voltage up to 4kV (5/50ns)
- > Residual voltage max. 50V at 3kV Surge
- > Compatible to PoE and PoE+ requirements
- > DUT/AE connection via RJ45 connectors

APPLICATION AREAS

-  TELECOM
-  INDUSTRY
-  RESIDENTIAL
-  MILITARY

TECHNICAL DETAILS

CNI 508N2 - COUPLING- DECOUPLING NETWORK

COUPLING NETWORK FOR COUPLING OF THE SURGE AND BURSTIMPULSE TO UNSHIELDED AND SHIELDED HIGH-SPEED COMMUNICATION LINES

The CNI 508N2 is specially designed for the testing of high-speed communication lines. It allows data transfers up to 1,000 Mbit / s without affecting the signal.

It also supports PoE and PoE + standard requirements as per IEEE 802.3af-2003 and IEEE 802.3at-2009.

The CNI 508N2 includes two surge pulse inputs. One for the direct coupling to lines and one for coupling to the cable shield (see tests to shielded cables as per IEC 61000-4-5).

Surge: Direct coupling

Using series resistors, as specified in the standard, the surge pulses are coupled onto the unshielded symmetrical Interconnection lines.

The coupling network includes all necessary resistors and coupling elements to couple the 1,2 / 50us impulse (max. 3 kV) up to 4 pairs of high-speed communication lines.

The picture below shows the normative design of the coupling-decoupling network.

Fig. 15 IEC 61000-4-5 (Ed. 2.0 :2005)
Fig. 11 IEC 61000-4-5 (Ed. 3.0 :2014)

Burst:

A separate coaxial input is used for couple the EFT /Burst impulse to shielded datalines. The decoupling part of the CNI 508N2 decouples the EFT pulses in direction to the AE Port.

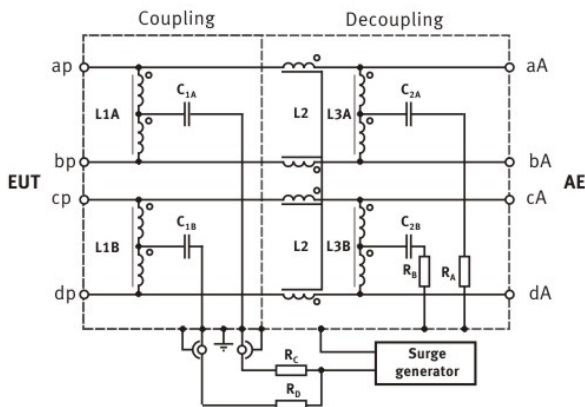

IEC 61000-4-5 (Ed. 2.0 : 2005) Fig. 15
IEC 61000-4-5 (Ed. 3.0 : 2014) Fig. 11

COUPLING TO THE SCREENED LINES

TEST OF SHIELDED LINES

Up today, the surge test on shielded data cable had a complicated and hazardous test setup with long cables and additional galvanically isolated power supplies.

With the innovative CNI 508N2 this test / test setup get much easier. The accessory is correct decoupled and the surge pulse is coupled directly to the shield of the tested cable and not applied to the conductive housing.

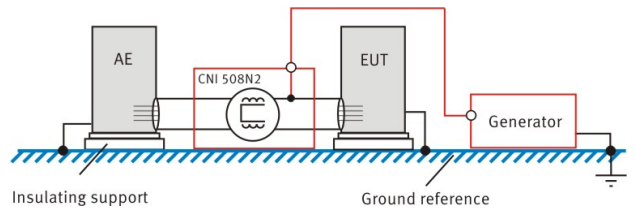

POE UND POE+ REQUIREMENTS

TEST SET-UP WITH POE AND POE+ SUPPLY

The power supply input for PoE and PoE + applications is on the protected side (AE) of the coupling / decoupling network.

The power supply is fed through the CNI 508N2 to the DUT. The voltage range for PoE and PoE + supplies is standardized from 36V to 57V.

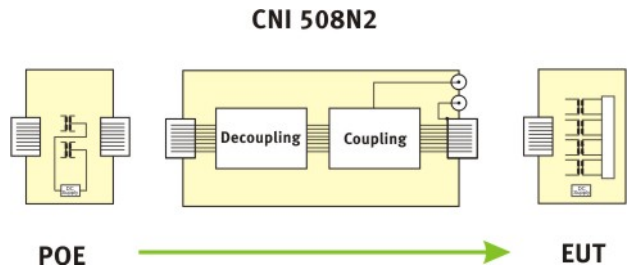

TECHNICAL DETAILS

CONNECTION AE PORT

DEVICE PROTECTION ON AE PORT

The impulse at the AE-port of the decoupling network is damped. The CNI 508N2 has an additional integrated overvoltage protection that limits the residual voltage below 40 V @2 kV and <50 V @4 kV between line and earth.

This protection level allows to use PoE (Power over Ethernet) power supply inside the specified voltages range from 36V to 57V.

This protection level is for some application cases too high and can destroy your expensive auxiliary equipment connected at the AE port. Thus EM TEST has developed an additional protective element SPN 508N1

SPN 508N1 SURGE PROTECTION OPTION

SURGE PROTECTION NETWORK FOR UNSHIELDED AND SHIELDED HIGH-SPEED COMMUNICATION LINES

The optional SPN 508N1 is required to appropriately decouple the surge pulses from the auxiliary equipment. The residual voltage at the AE port is limited to max. 10V@2kV surge voltage level. Its specific design allows the full data transfer up to 1000 MBit/s without causing signal degradation.

The CNI 508N2 limits the residual voltage to 40V. This voltage may destroy your precious accessories. The SPN 508N1 with its low protection level 10V is therefore the ideal protection for all other tests with high voltage.



CNI 508N2 - COUPLING/DECOUPLING NETWORK FOR SHIELDED AND UNSHIELDED LINES

SURGE TEST MODE

Coupling mode	shielded and unshielded cable with up to 4 pairs
Test voltage	Max. 3kV* (1.2/50us) (* only with connected RJ45 connector; if left open the max. test voltage is limited to 1.5kV)
Residual voltage	Max. 50V @3kV Surge, line - PE

BURST TEST MODE

Coupling mode	shielded cable with up to 4 pairs
Test voltage	Max. 4kV* (5/50ns) (* only with connected RJ45 connector; if left open the max. test voltage is limited to 1.5kV)
Residual voltage line - PE	Max. 40V @2kV Burst, Max. 60V @4kV Burst

TELECOM LINE SPECIFICATIONS

Input/Output	RJ45 female connectors for telecom lines
Terminal layout	Pair 1: pins 1/2 Pair 2: pins 3/6 Pair 3: pins 4/5 Pair 4: pins 7/8
Data rate	up to 1,000MBit/s
Protection	+ - 60V between two pairs
Operating voltage	max. 57VDC
Operating current	max. 1A

TECHNICAL DETAILS

CNI 508N2 - COUPLING/DECOUPLING NETWORK FOR SHIELDED AND UNSHIELDED LINES

INPUTS	
Surge shield	SHV connector
Surge unshielded	SHV connector
Burst	SHV connector

GENERAL DATA	
Dimensions	270mm x 110mm x 140mm (LxWxH)
Weight	6.5kg
Temperature	5°C - 40°C (operation)
Rel. humidity	10% - 90%, non condensing

OPTION SPN 508N1 - SURGE PROTECTION NETWORK FOR UNSHIELDED AND SHIELDED LINES

SURGE TEST MODE	
Number of lines	4 twisted pairs
Max. discharge current	2kA (8/20us) without destruction to the RJ45 contacts
Residual voltage	max. 10V
Insertion loss	< -1.5dB (300kHz - 100MHz)

TELECOM LINE SPECIFICATION	
Input/Output	RJ45 female connectors for telecom lines
Terminal layout	Pair 1: pins 1/2 Pair 2: pins 3/6 Pair 3: pins 4/5 Pair 4: pins 7/8
Data rate	up to 1,000MBit/s

GENERAL DATA	
Dimensions	115mm x 80mm x 80mm (LxWxH)
Weight	0.7kg
Temperature	5°C - 40°C (operation)
Rel. humidity	10% - 90%, non condensing

COMPETENCE WHEREVER YOU ARE



CONTACT EM TEST DIRECTLY

Switzerland

AMETEK CTS GmbH > Sternenhofstraße 15 > 4153 Reinach > Switzerland
 Phone +41 (0)61 204 41 11 > Fax +41 (0)61 204 41 00
 Internet: www.ametek-cts.com > E-mail: sales.conducted.cts@ametek.com

Germany

AMETEK CTS Europe GmbH > Customer Care Center EMEA > Lünener Straße 211
 > 59174 Kamen > Germany
 Phone +49 (0) 2307 26070-0 > Fax +49 (0) 2307 17050
 Internet: www.ametek-cts.com > E-mail: info.cts.de@ametek.com

Poland

AMETEK CTS Europe GmbH > Biuro w Polsce > ul. Twarda 44 > 00-831 Warsaw > Poland
 Phone +48 (0) 518 643 12
 Internet: www.ametek-cts.com > E-mail: Infopolska.cts@ametek.com

USA / Canada

AMETEK CTS US > 52 Mayfield Ave > Edison > NJ 08837 > USA
 Phone +1 732 417 0501
 Internet: www.ametek-cts.com > E-mail: usasales.cts@ametek.com

P.R. China

E & S Test Technology Limited > Rm 913, Leftbank >
 No. 68 Bei Si Huan Xi Lu > Haidian District > Beijing 100080 > P.R. China
 Phone +86 (0)10 82 67 60 27 > Fax +86 (0)10 82 67 62 38
 Internet: www.emtest.com > E-mail: info@emtest.com.cn

Republic of Korea

EM TEST Korea Limited > #405 > WooYeon Plaza > #986-8 > YoungDeok-dong >
 Giheung-gu > Yongin-si > Gyeonggi-do > Korea
 Phone +82 (31) 216 8616 > Fax +82 (31) 216 8616
 Internet: www.emtest.co.kr > E-mail: sales@emtest.co.kr

Singapore

AMETEK Singapore Pte. Ltd > No. 43 Changi South Avenue 2 > 04-01 Singapore
 48164
 Internet: www.ametek-cts.com > E-mail: singaporesales.cts@ametek.com

Great Britain

AMETEK GB > 5 Ashville Way > Molly Millars Lane > Wokingham > Berkshire
 RG41 2 PL > Great Britain
 Phone +44 845 074 0660
 Internet: www.ametek-cts.com

Information about scope of delivery, visual design and technical data correspond with the state of development at time of release. Subject to change without further notice.